

## Data sheet

# SONOMETER™1100

## Ultrasonic compact energy meter

### Description/Application

MID examination certificate  
no. : DE-10-MI004-PTB003



The SONOMETER™1100 is an ultrasonic static compact energy meter especially designed for heating, cooling or combined heating/cooling application in local and district energy systems.

The SONOMETER™1100 as a compact energy meter consists of the following components:

- Ultrasonic flow sensor;
- Calculator with integral hardware and software for measuring flow rate, temperature and energy consumption;
- Pair of temperature sensors.

### Features

- 1st. approval in Europe for ultrasonic energy meter with dynamic range of  $q_v/q_p$  1 : 250 in class 2 ( $q_p$  1.5 / 2.5 / 6 / 10 / 15 / 25 / 40 / 60 m<sup>3</sup>/h)
- Complete dynamic range:  $\geq 1 : 1500$
- Lithium battery, 230 V AC or 24 V AC mains unit
- Battery lifetime 11 years (16 years optional)
- Unique free- beam principle
- Improved service-friendly energy meter design
- Housings with thread and flange (PN 16 / 25)
- Can be configured for heating, cooling or combined heating/cooling application
- Temperature range: 5 - 130 / 150 °C
- Overload temperature up to 150 °C ( $q_p = 0.6 - 2.5$  m<sup>3</sup>/h)
- Swirl-free flow around reflector
- Lower pressure loss
- Robust stainless steel reflector
- Insensitive to dirt
- Available in nominal sizes  $q_p$  0.6 / 1.0 / 1.5 / 2.5 / 3.5 / 6 / 10 / 15 / 25 / 40 / 60 m<sup>3</sup>/h
- Measuring accuracy meets the requirements of EN 1434 (MID) class 2 and 3
- No calming sections necessary in the inlet and/or outlet (standard installation)

### Special Features

- Power save mode
- NOWA test capability
- Remote reading via M-Bus, L-Bus, RS 232, RS 485, Radio or optical interface
- Integrated Radio (868 or 434 Hz), Real Data or Open Metering Standard (OMS)
- Individual remote reading (Automatic Meter Reading) with add on modules Plug&Play
- 2 communication ports (e.g. M-Bus + M-Bus)
- Improved radio performance
- Individual tariff functions
- History memory for 24 months
- Extensive diagnostic displays
- IZAR@SET parameterization software on Windows basis guarantees optimum adaptation to the user's specific needs

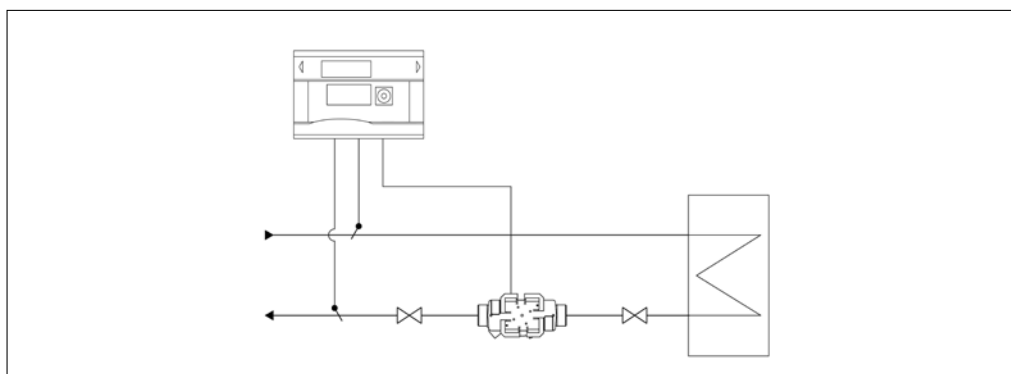

**Ordering:**

The ordering code no. consists of both dummy code and ordering code.

Dummy code: 087G6011

Ordering code:



**AAA - application**

energy meter for heating	1HE
energy meter for cooling	1CO
energy meter for heating/cooling	1HC

**BB - flow sensor**

qp 0.6 m <sup>3</sup> /h / 110 mm thread / DN 15 / G <sup>3</sup> / <sub>4</sub> B	1A
qp 0.6 m <sup>3</sup> /h / 130 mm thread / DN 20 / G1B	1B
qp 0.6 m <sup>3</sup> /h / 190 mm thread / DN 20 / G1B	1C
qp 1.0 m <sup>3</sup> /h / 110 mm thread / DN 15 / G <sup>3</sup> / <sub>4</sub> B	1D
qp 1.0 m <sup>3</sup> /h / 130 mm thread / DN 20 / G1B	1E
qp 1.0 m <sup>3</sup> /h / 190 mm thread / DN 20 / G1B	1F
qp 1.5 m <sup>3</sup> /h / 110 mm thread / DN 15 / G <sup>3</sup> / <sub>4</sub> B	1G
qp 1.5 m <sup>3</sup> /h / 130 mm thread / DN 20 / G1B	1H
qp 1.5 m <sup>3</sup> /h / 190 mm thread / DN 20 / G1B	1I
qp 2.5 m <sup>3</sup> /h / 130 mm thread / DN 20 / G1B	1J
qp 2.5 m <sup>3</sup> /h / 190 mm thread / DN 20 / G1B	1K
qp 3.5 m <sup>3</sup> /h / 260 mm thread / DN 25 / G1 <sup>1</sup> / <sub>4</sub> B	1L
qp 6 m <sup>3</sup> /h / 260 mm thread / DN 25 / G1 <sup>1</sup> / <sub>4</sub> B	1M
qp 10 m <sup>3</sup> /h / 300 mm thread / DN 40 / G2B	1N
qp 0.6 m <sup>3</sup> /h / 190 mm flange DN 20 <sup>1</sup>	2A
qp 1.0 m <sup>3</sup> /h / 190 mm flange DN 20 <sup>1</sup>	2B
qp 1.5 m <sup>3</sup> /h / 190 mm flange DN 20 <sup>1</sup>	2C
qp 2.5 m <sup>3</sup> /h / 190 mm flange DN 20 <sup>1</sup>	2D
qp 3.5 m <sup>3</sup> /h / 260 mm flange DN 25 <sup>1</sup>	2E
qp 3.5 m <sup>3</sup> /h / 260 mm flange DN 32 <sup>1</sup>	2F
qp 6 m <sup>3</sup> /h / 260 mm flange DN 25 <sup>1</sup>	2G
qp 6 m <sup>3</sup> /h / 260 mm flange DN 32 <sup>1</sup>	2H
qp 10 m <sup>3</sup> /h / 300 mm flange DN 40 <sup>1</sup>	2I
qp 15 m <sup>3</sup> /h / 270 mm flange DN 50 <sup>1</sup>	2J
qp 25 m <sup>3</sup> /h / 300 mm flange DN 65 <sup>1</sup>	2K
qp 40 m <sup>3</sup> /h / 300 mm flange DN 80 <sup>1</sup>	2L
qp 60 m <sup>3</sup> /h / 360 mm flange DN 100 <sup>1</sup>	2M

<sup>1</sup> only PN 25 possible!

**C - nominal pressure**

PN 16	C
PN 25 <sup>1</sup>	D

<sup>1</sup> flange versions must be PN 25

**D - cable length between calculator and flow sensor**

1.5 m (standard)	A
3 m	B
5 m <sup>1</sup>	C
0.2 m <sup>2</sup>	D

<sup>1</sup> not possible for qp 3.5 m<sup>3</sup>/h and qp to 6 m<sup>3</sup>/h versions  
<sup>2</sup> max. 90°C possible. Only for qp 0.6 - 2.5 versions

**E - installation**

low temperature	L
high temperature	H

**F - power supply**

battery 3.6 V DC (A-cell)	1
battery 3.6 V DC (D-cell) <sup>1</sup>	2
mains unit 230 V AC	3
mains unit 24 V AC	4

<sup>1</sup> for integrated radio

**GH - interface modules**

<b>modules slot 1</b>	
no module in slot 1	0
Analogue output module (4-20mA) <sup>1</sup>	A
Combined module (2 pulse inputs / 1 pulse output)	B
Pulse input module (2 inputs)	C
M-Bus module	D
L-Bus module (use for external radio)	E
RS232 module	F
RS485 module	G
<b>modules slot 2</b>	
no module in slot 2	0
Pulse output module <sup>2</sup>	A
Combined module (2 pulse inputs / 1 pulse output) <sup>2</sup>	B
Pulse input module (2 inputs) <sup>2</sup>	C
M-Bus module <sup>2</sup>	D
L-Bus module (use for external radio) <sup>2</sup>	E
RS232 module <sup>2</sup>	F
RS485 module <sup>2</sup>	G

<sup>1</sup> only one module possible  
<sup>2</sup> integrated radio is not available

**P - version of communication**

without radio	0
Radio 868 MHz Real Data	1
Radio 434 MHz Real Data	2
Radio 868 MHz Open Metering Standard	3
Radio 434 MHz Open Metering Standard	4

**O - verification**

0	without approval mark
1	compliant according to national regulations
3	compliant to MID. No letter of conformity (initial verification)
4	compliant to MID. With letter of conformity (initial verification)
5	compliant to MID. With letter of conformity (initial verification) and additional test reports

**NN - country code**

00	Neutral code with docs in English
AT	Austria
BA	Bosnia
BG	Bulgaria
CN	China
DK	Denmark
EE	Estonia
HR	Croatia
CZ	Czech Republic
DE	Germany
GB	United Kingdom
IE	Ireland
IT	Italy
KZ	Kazakhstan
LV	Latvia
LT	Lithuania
MD	Moldova
MK	Macedonia
PL	Poland
RO	Romania
RU	Russia
CS	Serbia
SK	Slovak Republic
SI	Slovenia
TR	Turkey
UA	Ukraine
XM	Montenegro

**M - connections (sets)**

0	without
1	screwing set R 1/2" x G 3/4 B
2	screwing set R 3/4" x G 1 B
3	screwing set R 1" x G 1 1/4 B
4	screwing set R 1 1/2" x G 2 B

**L - accessories / pocket**

0	without	
<b>for ø 5.2 mm temperature sensors (pair)<sup>1</sup></b>		
F	brass-pockets, 35 mm, MID <sup>3</sup>	DN 15-32
G	brass-pockets, 52 mm, MID	DN 40-65
H	brass-pockets, 85 mm, MID	DN 80-125
I	brass-pockets, 120 mm, MID	DN 150-200
<b>for ø 6.0 mm temperature sensors (pair)</b>		
V	brass-pockets, 40 mm MID	DN 25-65
W	brass-pockets, 85 mm MID	DN 80-125
X	brass-pockets, 120 mm MID	DN 150-200
Y	stainless steel-pockets, 85 mm MID	DN 80-125
Z	stainless steel-pockets, 120 mm MID	DN 150-200
1	stainless steel-pockets, 155 mm MID	DN 200-250
2	stainless steel-pockets, 210 mm MID	DN 300
<b>Accessories</b>		
R	ball valve DN 15 - 1/2" for direct sensor <sup>2</sup>	(1 piece)
S	ball valve DN 20 - 3/4" for direct sensor <sup>2</sup>	(1 piece)
T	ball valve DN 25 - 1" for direct sensor <sup>2</sup>	(1 piece)
U	adapter for mounting direct sensor R 1/2" M 10x1 <sup>2</sup>	

<sup>1</sup> versions with one sensor pocket on request

<sup>2</sup> not possible for ø 6.0 mm sensors

<sup>3</sup> max temperature: 105°C

**K - temperature sensor mounting**

1	qp 0.6 - 2.5 : one sensor mounted in the flow sensor <sup>1</sup>
2	qp 3.5 - 60 : indirect mounting (2 free sensors)
3	qp 0.6 - 2.5 : indirect mounting (2 free sensors)
3	qp 3.5 - 25 : one sensor mounted in the flow sensor <sup>1</sup>

<sup>1</sup> only for ø 5.2 mm sensors

**J - temperature sensors (pair)**

0	10 m cable as accessory
N	Pt 500 / ø 5.2 mm / 2 m cable, MID
O	Pt 500 / ø 5.2 mm / 3 m cable, for cooling
P	Pt 500 / ø 5.2 mm / 5 m cable, MID
S	Pt 500 / ø 5.2 mm / 2 m cable PUR, MID
T	Pt 500 / ø 6.0 mm / 2 m cable, MID
V	Pt 500 / ø 6.0 mm / 5 m cable, MID

**I - energy units**

A	kWh (without digit after comma) only for 0.6 - 6 m <sup>3</sup> /h
B	MWh (with 1 digit after comma)
C	MWh (with 2 digit after comma)
D	MWh (with 3 digit after comma) only for 0.6 - 6 m <sup>3</sup> /h
E	GJ (with 1 digit after comma)
F	GJ (with 2 digit after comma)
G	GJ (with 3 digit after comma) only for 0.6 - 6 m <sup>3</sup> /h
H	Gcal (with 1 digit after comma)
I	Gcal (with 2 digit after comma)
J	Gcal (with 3 digit after comma) only for 0.6 - 6 m <sup>3</sup> /h
K	MBtu (with 1 digit after comma)
L	MBtu (with 2 digit after comma)
M	MBtu (with 3 digit after comma) only for 0.6 - 6 m <sup>3</sup> /h

**Ordering continued**

Modules

	Designation	Code No.
Communication	M-Bus module	<b>3022071</b>
	L-Bus module (use for external radio)	<b>3022072</b>
	RS232 module	<b>3022100</b>
	RS485 module	<b>3022101</b>
Function	Analogue output module (4-20mA)	<b>3022106</b>
	Combined module (2 pulse inputs/ 1 pulse output)	<b>3022075</b>
	Pulse input module (2 inputs)	<b>3022074</b>
	Pulse output module (2 outputs)	<b>3022073</b>
Supply voltage	battery 3.6 V DC (A-cell)	<b>3022102</b>
	battery 3.6 V DC (D-cell)	<b>3022103</b>
	mains unit 230 V AC	<b>3022076</b>
	mains unit 24 V AC	<b>3022079</b>

**Accessories**

Temperature sensors

	Temperature sensors (pair)	pair	Code No.
	Pt 500 / ø 5.2 mm / 10 m cable, MID	1	<b>3002679</b>
	Pt 500 / ø 6.0 mm / 10 m cable, MID	1	<b>3004697</b>

Ball valves

	Dimension (IG)	Set	Code No.
	G ½"	12 pcs	<b>087H0118</b>
	G ¾"	12 pcs	<b>087H0119</b>
	G 1"	12 pcs	<b>087H0120</b>

Adapter for mounting temperature sensors

	Coupling thread	Sensor thread	Set	Code No.
	R ½"	M 10 x 1	32 pcs	<b>087H0107</b>

Tailpieces

	Threaded	Dimension (AGR x IG)	Set	Code No.
		R ½" x G ¾ B	5 pcs	<b>3005674</b>
		R ¾" x G 1 B	5 pcs	<b>3013183</b>
		R 1" x G 1¼ B	5 pcs	<b>3013185</b>
		R 1½" x G 2 B	5 pcs	<b>3013184</b>

Software

The IZAR@SET parameterization software on windows basis is a convenient tool for handling the energy meter. The IZAR@SET software is available on web site [www.hydrometer.de](http://www.hydrometer.de).

It is used for:

- commissioning
- reading out measured values
- printing out energy meter logs
- energy meter configuration
- application analysis
- print the meter protocol

**Technical data**

Flow rate ranges	Nominal	$q_p$ m <sup>3</sup> /h	<b>0.6</b>			<b>1.0 / 1.5</b>			<b>2.5</b>			<b>3.5</b>			<b>6</b>			<b>10</b>			<b>15</b>			<b>25</b>			<b>40</b>			<b>60</b>		
	Maximum	$q_s$ m <sup>3</sup> /h	1.2			2 / 3			5			7			12			20			30			50			80			120		
	Minimum	$q_i$ l/h	6			10 / 6			10			35			24			40 <sup>1)</sup> / 100			60 <sup>1)</sup> / 150			100 <sup>1)</sup> / 150			160			240 <sup>1)</sup> / 600 <sup>2)</sup> / 1200		
	Starting	l/h	1			2.5			4			7			7			20			40			50			80			120		
Diameter	Nominal	DN mm	15	20			15	20			20			25	32			25	32			40	50	65	80	100						
	Connection	AGZ	G 3/8B	G 1B	FL	G 3/8B	G 1B	FL	G 1B	FL	G 1 1/4B	FL	G 1 1/4B	FL	G 2B	FL	FL	FL	FL	FL	FL	FL	FL	FL								
	Tailpiece	AGV	R 1/2	R 3/4	-	R 1/2	R 3/4	-	R 3/4	-	R 1	-	R 1	-	R 1 1/2	-	-	-	-	-	-	-	-	-								
Operating pressure	PN bar	16 / 25			25	16 / 25			25	16 / 25			25	16 / 25			25	16 / 25			25	25	25	25	25	25	25	25	25			
Flow sensor Temp. range	heating	°C	5...130												5...150																	
	cooling		5...50												5...50																	
	heat./cool.		5...105												5...105																	
Medium	circulation water (pH-value: 7 - 10)																															
Pressure loss	At $q_p$	$\Delta p$ mbar	85			36 / 75			100			44			128			95	80	75	80	75										
Overall length	mm	110	130	190	110	130	190	130	190	260			260			300			270	300	300	360										
Miscellaneous	Complete weight	kg	0.75	0.76	0.78	2.85	0.75	0.76	0.78	2.85	0.76	0.78	2.85	1.50	3.50	4.80	1.50	3.50	4.80	3.0	6.80	7.60	9.60	11.20	17.00							
Input	Temperature sensors	Type	Pt 500 with 2-wire leads																													
	Sensor current	mA	Pt 500 peak < 2; rms < 0.012																													
	Measuring cycle	T s	Mains unit supply: 2 A-cell battery: 16; D-cell battery: 4																													
	Max. temperature difference	$\Delta\theta_{max}$ K	177																													
	Min. temperature difference	$\Delta\theta_{min}$ K	3																													
	Starting temperature difference	$\Delta\theta$ K	0.125																													
	Absolute temperature measuring range	$\theta$ °C	1...180																													
Supply voltage	Operating voltage	$U_N$	3.6 V DC (Lithium-battery) / 230 V AC / 24 V AC																													
Basic features	Ambient class	EN 1434 class E1 + M1																														
	Protection class	calculator: IP 54 flow sensor: IP 54 (heating) / IP 68 (cooling)																														
	Type	Static energy meter to EN 1434 (MID)																														
	Measuring process	Ultrasonic volume measurement																														
Display indication	Display	LCD, 8-digit																														
	Units	MWh - kWh - GJ - Gcal - MBtu - gal - GMP - °C - °F - m <sup>3</sup> - m <sup>3</sup> /h																														
	Total values	99 999 999 - 9999 999.9 - 999 999.99 - 99 999.999																														
	Values displayed	Power - energy - flow rate - temperature - volume																														

<sup>1)</sup> Only for horizontal installation

<sup>2)</sup> Only in rising or falling pipes or tilted installation

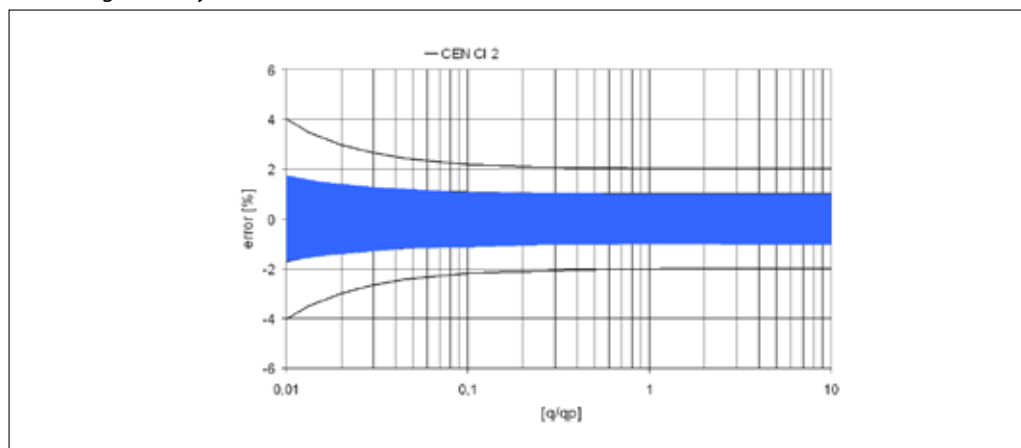
**Measuring accuracy to EN 1434 Class 2**

**Design and function**

The SONOMETER™1100 as a compact energy meter consists of the following components:

- Ultrasonic flow sensor;
- Calculator with integral hardware and software for measuring flow rate, temperature and energy consumption;
- Pair of temperature sensors.

The calculator contains all the necessary circuits for recording the flow rate and temperature and for calculating, logging and displaying the data. The calculator housing can be mounted directly on the flow sensor or on the wall. The energy meter can be conveniently read from a single-line 8-digit display with units and symbols. A push-button provides user-friendly control of the various display loops. All failures and faults are recorded automatically and shown on the LC display. To protect the reading data, all the relevant data are saved in a non-volatile memory (EEPROM). This memory saves the measured values, device parameters and types of error at regular intervals.

**Ultrasonic flow sensor**

The ultrasonic technology of the flow sensor permits very high measuring accuracy and can be used in the supply or return line. The flow sensor meets the requirements of EN 1434 / class 2 and 3. The standard cable length between the calculator and the flow sensor is 1.5 m (optional 5 m).

Supply voltage:

- Lithium battery 3.6 V DC A-cell (11 years typical lifetime)
- Lithium battery 3.6 V DC D-cell (16 years typical lifetime)
- Mains unit 230 V AC or 24 V AC with changeable backup battery

**Temperature Sensors**

Pairs of Pt 500 temperature sensors with 2-wire leads are used.

**Integrated Radio**

Integrated Radio is an interface for communication with radio receiver.

- Frequency band: 868 or 434 MHz
- Type of radio telegram: Real Data or Open Metering Standard (OMS)
- Transmission data updating: Online - no time delay between value measurement and data transmission
- Data transmission: Unidirectional
- Sending interval: 12...20 s; depending on length of telegram (duty cycle)

**Interfaces**

- Optical: ZVEI interface as standard, for communication and testing, M-Bus protocol.
- M-Bus: Configurable telegram, according to EN1434-3. Data reading and parametrization are via two wires with polarity reversal protection.
- L-Bus: Adapter for external radio module; configurable telegram, according to EN1434-3. Data reading and parametrization are via two wires with polarity reversal protection. M-Bus protocol.
- RS232: Serial interface for communication with external devices. A special data cable is required. M-Bus protocol.
- RS485: Serial interface for communication with external devices. Power supply with 12V ± 5V. M-Bus protocol.
- Pulse output: Module with 2 Open Collector pulse outputs (potential-free), 4 Hz (pulse width 125ms), 100 Hz (pulse width ≥5ms), ratio: pulse duration / pulse break ~ 1:1. Configurable via IZAR@SET software. Possible pulse output values are Energy, Volume, Tariff energy 1, Tariff energy 2, Tariff condition 1, Tariff condition 2, Energy error and Volume error.

- Pulse input: Module with 2 pulse inputs, max. 20 Hz with minimum pulse duration of 10 msec, input resistance 2.2 M Ohms, terminal voltage 3V DC, cable length up to maximum 10m. The pulse value and the unit is configurable for energy, water, gas or electrical meter by IZAR@SET. Data can be transferred remotely. Also two accounting day's are available for both inputs.
- Combined pulse input / output: Module with 2 pulse inputs and 1 pulse output. Configurable via IZAR@SET software.
- Analogue output: Module for 4...20 mA with 2 programmable passive outputs, programmable value in case of error. Output values can be power, flow rate, temperatures. Configurable via IZAR@SET software.

**Slot 1**

- Analogue output module (4-20mA)
- Combined module (2 pulse inputs / 1 pulse output)
- Pulse input module (2 inputs)
- M-Bus module
- L-Bus module (use for external radio)
- RS232 module
- RS485 module

**Slot 2**

- Pulse output module
- Combined module (2 pulse inputs / 1 pulse output)
- Pulse input module (2 inputs)
- M-Bus module
- L-Bus module (use for external radio)
- RS232 module
- RS485 module

**Event Memory**

Events such as changes and faults are stored in a non-volatile memory with a capacity of up to 127 entries. The following events are recorded:

- Checksum error
- Temperature measurement error
- Ultrasonic operating time measurement errors
- Start and end of test mode
- Changing of the main configuration

**Monthly Memory**

The SONOMETER™1100 has a history memory of 24 months. The following values are stored in the EEPROM on the programmable interval (daily, weekly, monthly):

- Date/ Time
- Cumulated energy
- Tariff energy 1
- Tariff energy 2
- Tariff definition 1
- Tariff definition 2
- Cumulated volume
- Error hour counter
- Value of max. flow
- Time max. flow
- Date max. flow
- Value of max. power
- Time max. power
- Date max. power
- Pulse input counter 1
- Pulse input counter 2
- Pulse 1 definition
- Pulse 2 definition
- Operating days
- Max. forward temperature
- Time max. forward temperature
- Date max. forward temperature
- Max. return temperature
- Time max. return temperature
- Date max. return temperature

**Design and function, continued**

**Log Memory**

The large two log memory blocks are used to store consumption values. The storage frequency can be selected from various storage intervals (1, 2, 3, 4, 5, 6, 10, 12, 15, 20, 30, 60 minutes or the default setting of 24 hours, Day in the month, Day of the week, (1024 seconds), 15th or end of month).

The data saved in the log memory can be used for the following analyses:

- Reading the calculator on a certain day.  
Example: If the day for reading is 01.10, the calculator reading is displayed for the period from 01.10 of the previous year to 30.09 of the current year.
- Comparison of the last consumption period with the preceding period

Extract of possible log memory settings

Memory block	Storage interval	Values	Date block size example	Number of data records	Recording period
area 1	1 hour	Error status, overload time temperature, overload time flow rate, supply temperature, return temperature, date and time, energy, tariff energy 1, tariff energy 2, tariff definition 1, tariff definition 2, volume, error day counter	16 byte	556	23 days
area 2	24 hours		16 byte	299	299 days
area 1	1 hour		8 byte	1113	46 days
area 2	24 hours		8 byte	599	599 days

**Max. Actual Values Memories**

The calculator creates maximum values for power, flow rate and temperatures based on consumption time, which are stored in the EEPROM. The integration intervals are adjustable to 6, 15, 30 or 60 minutes, 24 hours (and 1024 seconds). Default setting is 60 minutes.

**Tariff Function**

The calculator offers four optional tariff memories for monitoring plant load states for limit tariffs. Extensive tariff conditions make it possible to adapt the energy meter individually to the required customer-specific applications. The following limit types are possible: (This example applies to the display with 3 decimal places)

Type	LIMIT	LIMIT resolution
ΔT	1 ... 255 °C	1 °C
T <sub>R</sub> T <sub>F</sub>	1 ... 255 °C	1 °C
P	1 ... 255 kW	1 kW
Q	100 ... 25 500 l/h	100 l/h
Z		15 minutes

According to above table the energy or the time (in hours) how long the tariff condition is fulfilled will be stored in the tariff memories.

**Display Control**

The readings are displayed on the calculator by a 8-digit LCD with units and symbols.

**Loop Structure**

The SONOMETER™1100 display has six loops. Some display windows consist of two (to maximum seven) displays that are shown alternately at 4-second intervals. Some pictures in loops or a complete loop can be deactivated separately.



For quick visual guidance, the loops in the display are numbered from 1 to 6.

The main loop with the current data, e.g. for energy, volume and flow rate is programmed as default setting.

Overview of Loops

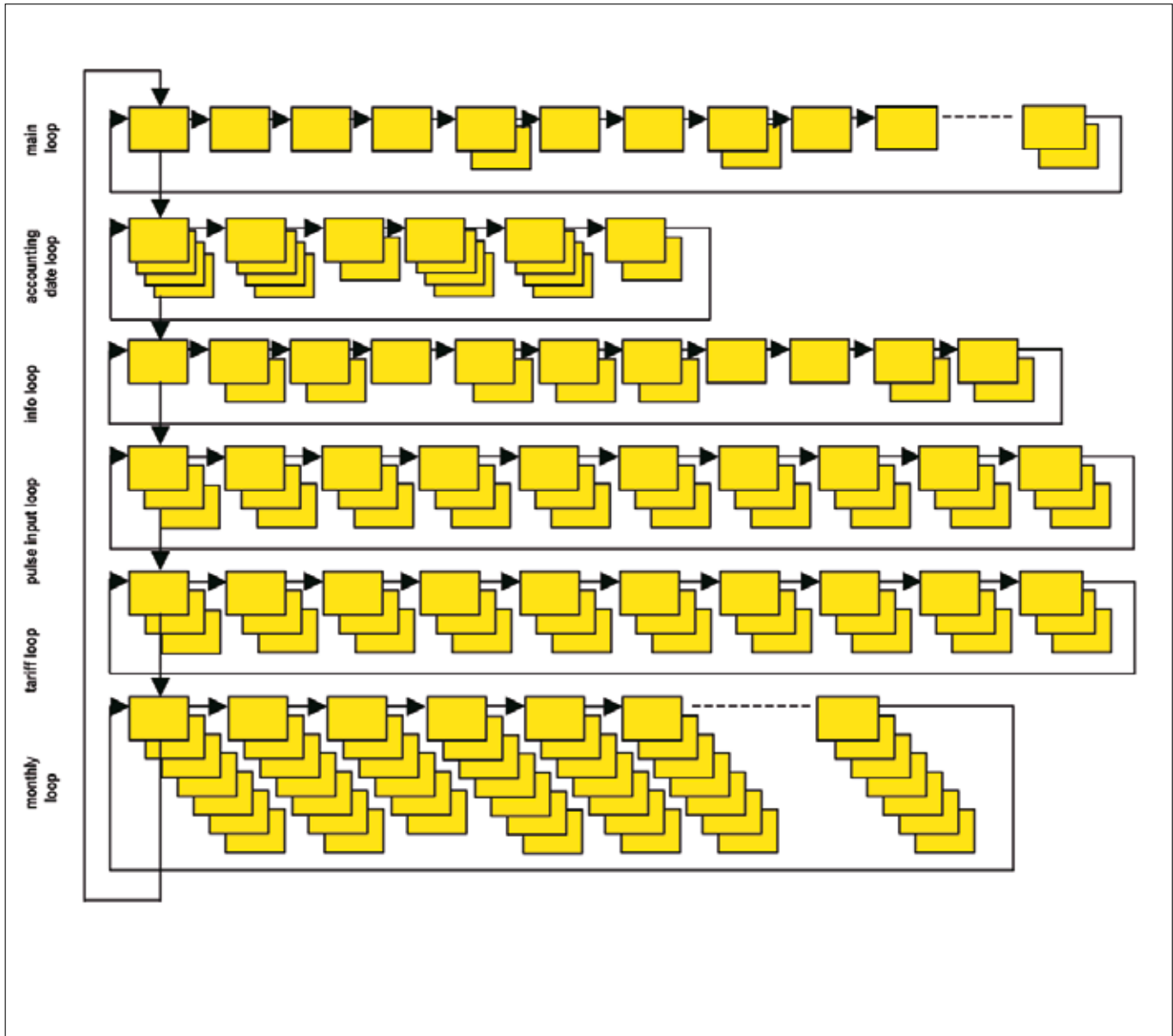

**Informative Displays (Standard)**

Loop	Sequence	Window 1	Window 2	Window 3	Window 4
"1" Main loop	1.1	Accumulated energy			
	1.2	Volume			
	1.3	Flow			
	1.4	Power			
	1.5	Forward / - return temperature			
	1.6	Difference temperature			
	1.7	Operating days			
	1.9	Error status			
	1.10	Display test			
	Loop	Sequence	Window 1	Window 2	Window 3 [off]
"2" Accounting date loop	2.1	Accounting date 1 date	Accounting date 1 energy	Accounting date 1 volume	,Accd 1A'
	2.2	Next accounting date 1 date	Next accounting date 1 energy	Next accounting date 1 volume	,Accd 1L'
	2.3	Previous accounting date 1 date	Previous accounting date 1 energy	Previous accounting date 1 volume	,Accd 1'
	2.4	,Accd 1'	Date of next accounting date 1		
	2.5	Accounting date 2 date	Accounting date 2 energy	Accounting date 2 volume	,Accd 2A'
	2.6	Next accounting date 2 date	Next accounting date 2 energy	Next accounting date 2 volume	,Accd 2L'
	2.7	Previous accounting date 2 date	Previous accounting date 2 energy	Previous accounting date 2 volume	,Accd 2'
	2.8	,Accd 2'	Date of next accounting date 2		
Loop	Sequence	Window 1	Window 2	Window 3	Window 4
"3" Info loop	3.1	Current date			
	3.2	,SEC_Adr'	Secondary address		
	3.3	,Pri_Adr 1'	Primary address 1		
	3.4	,Pri_Adr 2'	Primary address 2		
	3.5	Installation position			
	3.6	,Port 1'	No. of the mounted module at port 1		
	3.7	,Port 2'	No. of the mounted module at port 2		
	3.8	Status integrated radio	(Sequence will be shown only in meters with integrated radio)		
	3.9	No. of error hours			
	3.10	,F01-001' (software version)	Checksum		
Loop	Sequence	Window 1	Window 2	Window 3	Window 4
"4" Pulse input loop	4.1	,In1'	Accumulated values pulse input 1	,PPI' pulse value 1	
	4.2	,In2'	Accumulated values pulse input 2	,PPI' pulse value 2	

[off] = not active



Loop	Sequence	Window 1	Window 2	Window 3	Window 4	Window 5	Window 6	Window 7
"5" Tariff loop	The tariff loop is switched off as a standard at the heat meter or meter for cooling.							
Loop	Sequence	Window 1	Window 2	Window 3 [off]	Window 4 [off]	Window 5	Window 6	Window 7
"6" Monthly value loop	6.1	,LOG'	date last month			energy	volume	
	6.2	,LOG'	date month - 1			energy	volume	
	6.3	,LOG'	date month - 2			energy	volume	
	...	...						
	6.24	,LOG'	date month - 23			energy	volume	

[off] = not active

### Simple operation

A push-button mounted on the front of the calculator is used to switch to the various displays. The button can be pressed for a short or long time. A short press of the button (< 3 seconds) switches to the next display within a loop and a long press (> 3 seconds) switches to the next display loop. The "Energy" window (sequence 1.1) in the main loop is the basic display.

The calculator switches automatically to power save mode if the button is not pressed for approx. 4 minutes and returns to the basic display when the button is pressed again. The loop settings can be programmed to suit the customer's individual requirements using the IZAR@SET software.

**Mounting**

Depending on the design, the energy meter is installed either in the low temperature or high temperature line as indicated on the type plate. The energy meter is to be installed so that the direction of flow corresponds to the direction of the arrow on the flow sensor. Ensure that the flow sensor is always filled with liquid on completion of installation. **Straight inlet/outlet pipes (calming sections) are not required for the flow sensor.** The energy meter can be installed in both horizontal and vertical pipe sections, but every time so that air bubbles cannot collect in the flow sensor. For low flow we recommend to mount the flow sensor tilted 90° into the pipe.

Make sure the energy meter is installed sufficiently far away from possible sources of electromagnetic interference (switches, electric motors, fluorescent lamps, etc.). For cooling application and for medium temperatures more than 90° C, the calculator must be mounted on the wall at a sufficient distance away from heat sources using the holder supplied. It is recommended that stop valves be fitted before and after the energy meter to simplify dismantling the energy meter. The energy meter should be installed in a convenient position for service and operating personnel.

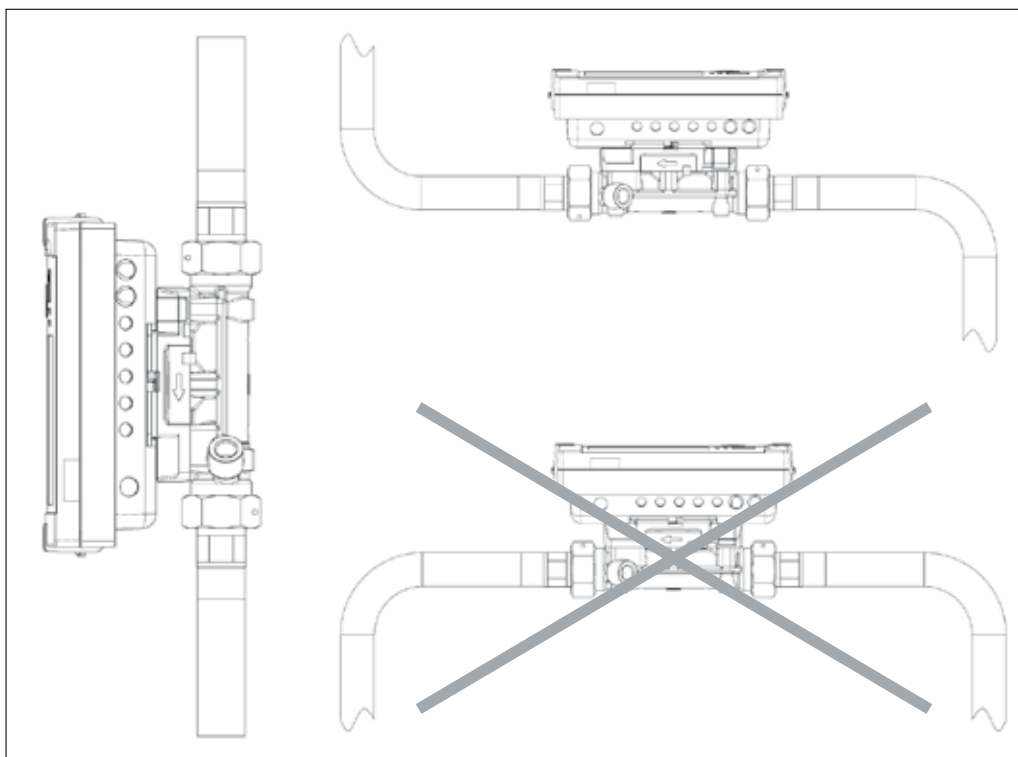

For the further information pls. refer to the SONOMETER™1100's instructions.

Dimensions

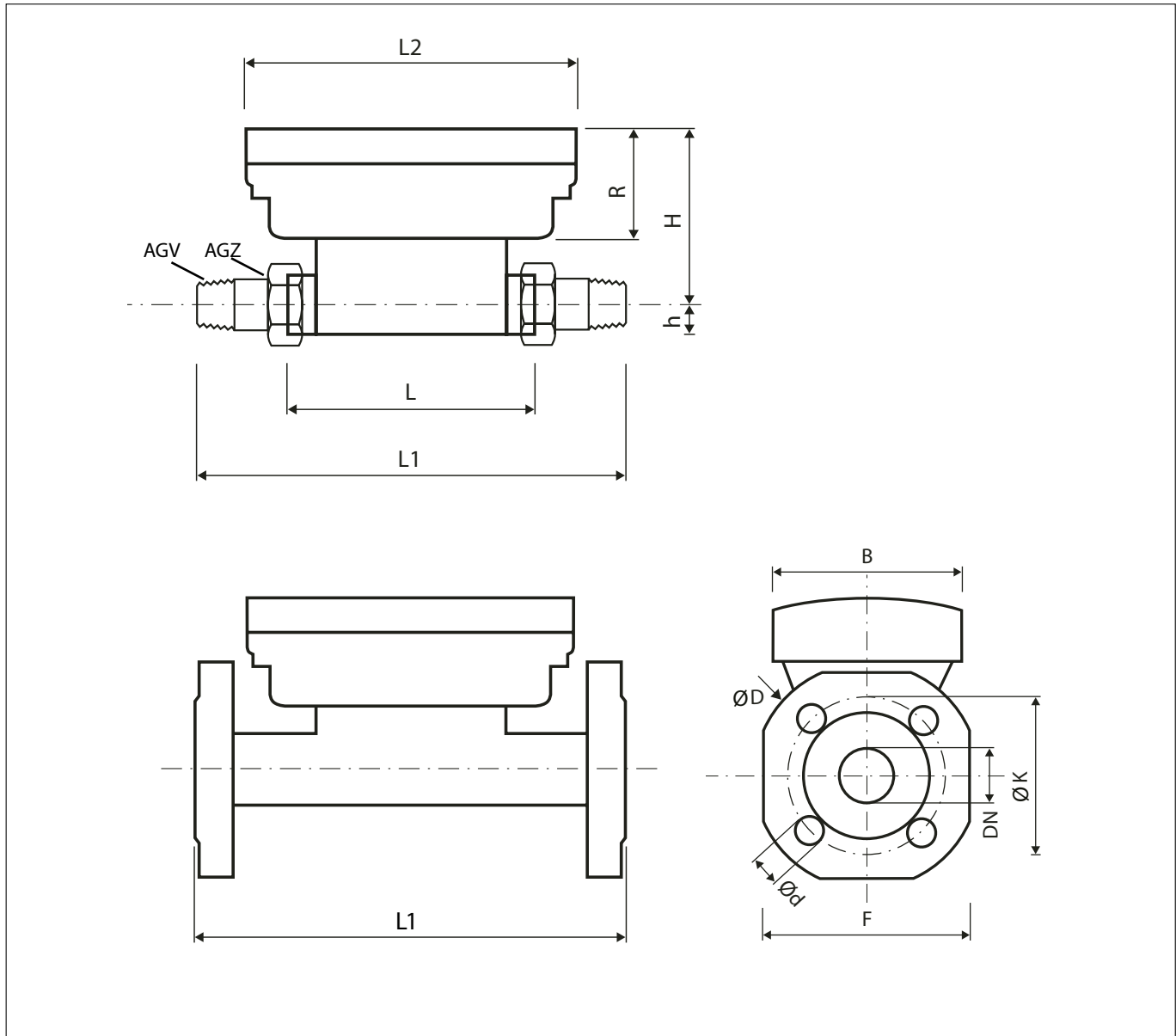

Nominal size	$q_p = 0.6 \text{ m}^3/\text{h}$				$q_p = 1.0 / 1.5 \text{ m}^3/\text{h}$				$q_p = 2.5 \text{ m}^3/\text{h}$				$q_p = 3.5 \text{ m}^3/\text{h}$				$q_p = 6 \text{ m}^3/\text{h}$			$q_p = 10 \text{ m}^3/\text{h}$		$q_p = 15 \text{ m}^3/\text{h}$		$q_p = 25 \text{ m}^3/\text{h}$		$q_p = 40 \text{ m}^3/\text{h}$		$q_p = 60 \text{ m}^3/\text{h}$
L [mm]	110	130	190	190	110	130	190	190	130	190	190	260	260	260	260	260	260	300	300	270	300	300	300	360				
L1 [mm]	190	230	290	190	190	230	290	190	230	290	190	380	260	260	260	380	260	440	300	270	300	300	300	360				
L2 [mm]	150								150								150											
B [mm]	100								100								100											
R [mm]	54								54								54											
H [mm]	82	84	84	84	82	84	84	84	84	84	84	88.5	88.5	88.5	88.5	88.5	88.5	94	94	99	106.5	114	119					
h [mm]	14.5	18	18	47.5	14.5	18	18	47.5	18	18	47.5	23	50	62.5	23	50	62.5	33	39	73.5	85	92.5	108					
AGZ	G3/8B DN 15	G1B DN 20	G1B DN 20	FL DN 20	G3/8B DN 15	G1B DN 20	G1B DN 20	FL DN 20	G1B DN 20	G1B DN 20	FL DN 20	G1/4B DN 25	FL DN 25	FL DN 32	G1/4B DN 25	FL DN 25	FL DN 32	G2B DN 40	FL DN 50	FL DN 65	FL DN 80	FL DN 100						
AGV	R1/2	R3/4	R3/4	-	R1/2	R3/4	R3/4	-	R3/4	R3/4	-	R1	-	-	R1	-	-	R1/2	-	-	-	-	-					
D [mm]	-	-	-	105	-	-	-	105	-	-	105	-	114	139	-	114	139	-	148	163	184	200	235					
d [mm]	-	-	-	14	-	-	-	14	-	-	14	-	14	18	-	14	18	-	18	18	18	19	22					
F [mm]	-	-	-	95	-	-	-	95	-	-	95	-	100	125	-	100	125	-	138	147	170	185	216					
K [mm]	-	-	-	75	-	-	-	75	-	-	75	-	85	100	-	85	100	-	110	125	145	160	190					
Weight [kg]	0.76	0.85	0.96	2.75	0.76	0.85	0.96	2.75	0.85	0.96	2.75	1.5	3.5	4.8	1.5	3.5	4.8	3	6.8	7.6	9.6	11.2	17					

**Dimensions, continued**

Temperature sensors

	Designation	Type	Dimension D (mm)	L (mm)
	Direct mounted	Pt 500	ø 5.2	45
	Pocket sensor	Pt 500	ø 5.2	45
ø 6.0			50	

Sensor pockets

	Type	Brass						Stainless steel					
	Sensor dimension (mm)	ø 5.2				ø 6.0		ø 6.0					
	Length	L <sub>1</sub> (mm)	47	60	93	128	47	92	128	98	133	168	223
		L (mm)	35	52	85	120	40	85	120	85	120	155	210

Danfoss can accept no responsibility for possible errors in catalogues, brochures and other printed material. Danfoss reserves the right to alter its products without notice. This also applies to products already on order provided that such alterations can be made without subsequential changes being necessary in specifications already agreed. All trademarks in this material are property of the respective companies. Danfoss and the Danfoss logotype are trademarks of Danfoss A/S. All rights reserved.