

AMI 140

Actuator for two point control

Description



AMI 140 is 2 point 3 wires actuator used with AB-QM (DN 10-32) and VZ, VZL, VRBZ valves. The actuator can be used with fan coil units, induction units, small re-heaters, re-coolers and zone applications in which hot/cold water is the controlled medium. The actuator provides with factory default setting (actuators spindle fully stem up):

- normally closed function for AB-QM and
- normally open function for VZ, VZL, and VRBZ

Note: it is possible to change setting from normally closed to normally open function (see "Wiring" part jumper setting, page 2.

Main data:

- 2-point 3 wires versions
- Force switch-off at stem down position prevents overload of actuator and valve
- No tools required for mounting
- Maintenance free during lifetime
- Low noise operation
- Supplied with 1.5 m cable.

Ordering

Type	Supply voltage	Speed	Code No.
AMI 140	24 V~	12 s/mm	082H8048
	230 V~		082H8049

Spare parts

Type	Code No.
Cable (5m) - 24 V	082H8052
Cable (5m) - 230 V	082H8053

Technical data

Power supply	24 Vac, 230 Vac; +10 to -15%
Power consumption	1 VA - 24 Vac; 8 VA - 230 Vac
Frequency	50 Hz / 60 Hz
Close of force	200 N
Stroke	5.5 mm
Speed	12 s/mm
Max. medium temperature inside the pipe	130 °C
Ambient temperature	0 ... 55 °C
Storage and transport temperature	-40 ... +70 °C
Protection code	IP 42
Weight	0.3 kg
CE - marking in accordance with standards	Low Voltage Directive 73/23/EEC, EMC-Directive 2006/95/EEC: - EN 60730-1, EN 60730-2-14

Installation

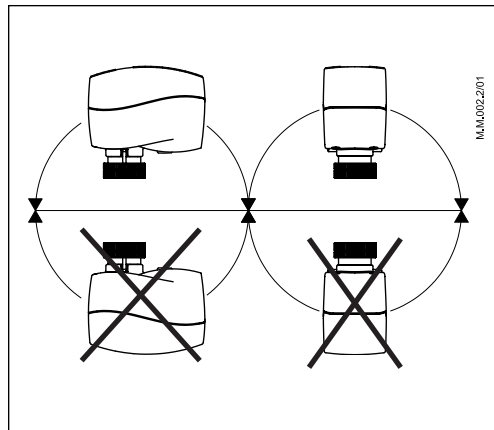

Mechanical

The actuator should be mounted with the valve stem in either horizontal position or pointing upwards.

The actuator is fixed to the valve body by means of a mounting ring which requires no tools for mounting. The ring should be tightened by hand.

Electrical

Important: It is strongly recommended that the mechanical installation is completed before the electrical installation.

Each actuator is supplied with the connecting cable for the controller.

Wiring

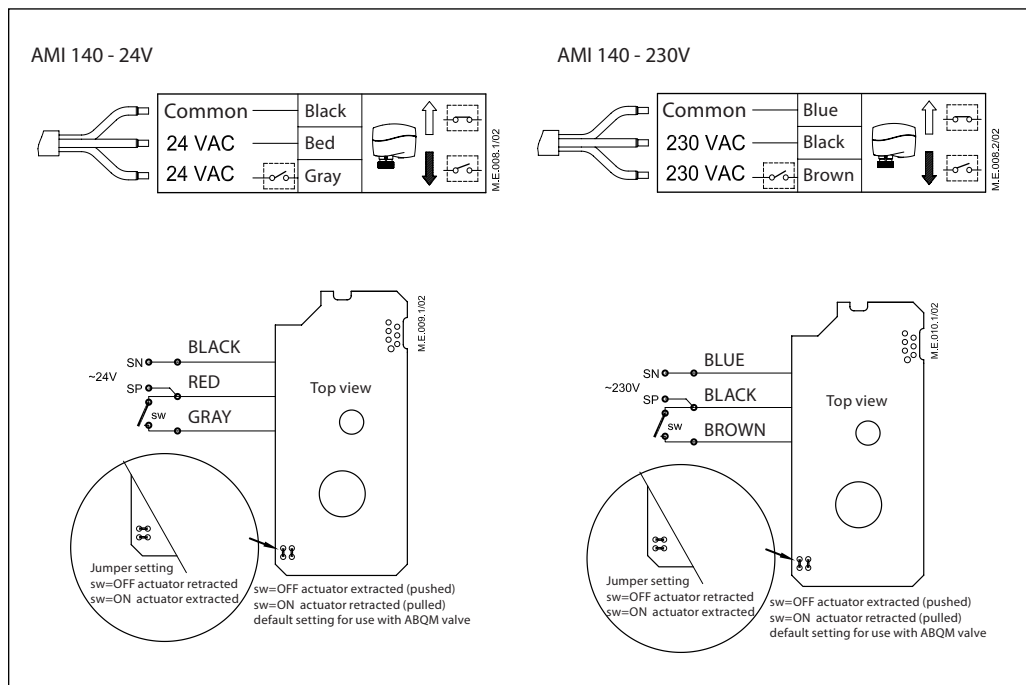

Disposal

The actuator must be dismantled and the elements sorted into various material groups before disposal.

Commissioning

The factory setting of the spindle is the fully stem up position because of easier mechanical connection of the actuator on the valve.

Installation and commissioning procedure
(if required)



Do not touch anything on the PCB! Before removing the cover in need of hand operation with Allen key power supply must be disconnected. Lethal voltage!

- a) Check the valve's neck. The actuator should be in steam up position (factory setting) ❶. Ensure that the actuator is mounted securely on the valve body.
- b) Energise the actuator according to the wiring diagram - see page 2.
- c) The direction of stem movement can be observed on the position indicator ❶.

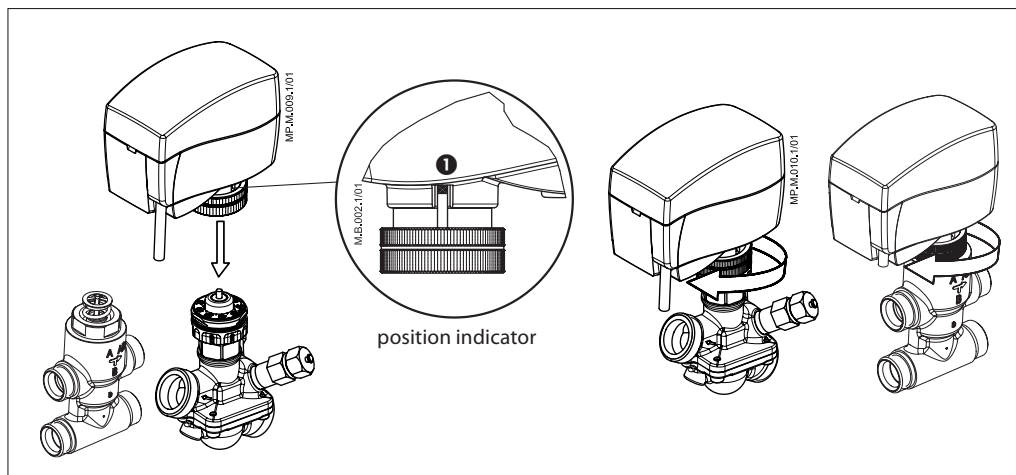

Manual override
(for service purposes only)



Caution:
Do not manually operate the drive under power!

1. Remove the cover.
2. Insert the Allen key 6mm into the spindle.
3. Press and hold the button (on the bottom side of the actuator) during manual override.
4. Pull out the tool.
5. Place cover back on the actuator.

Remark:

A "click" sound after energizing the actuator means that the gear wheel has jumped into normal position.

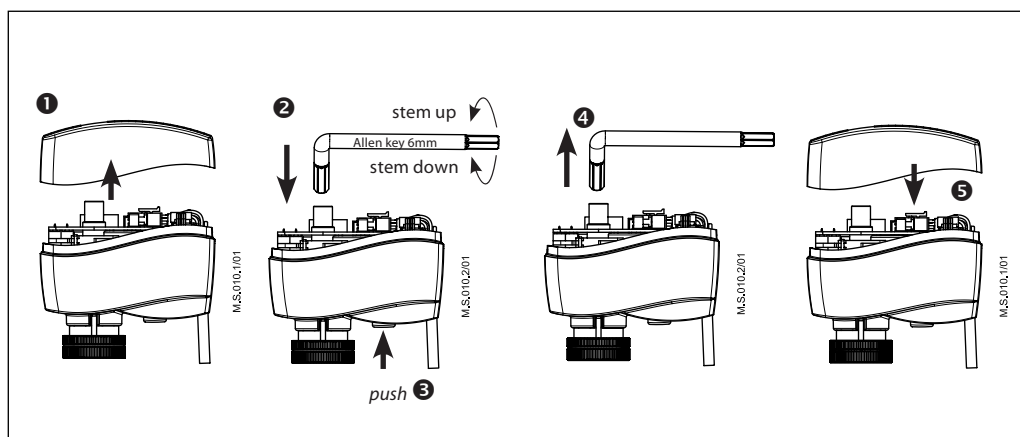

Actuator - valve combinations

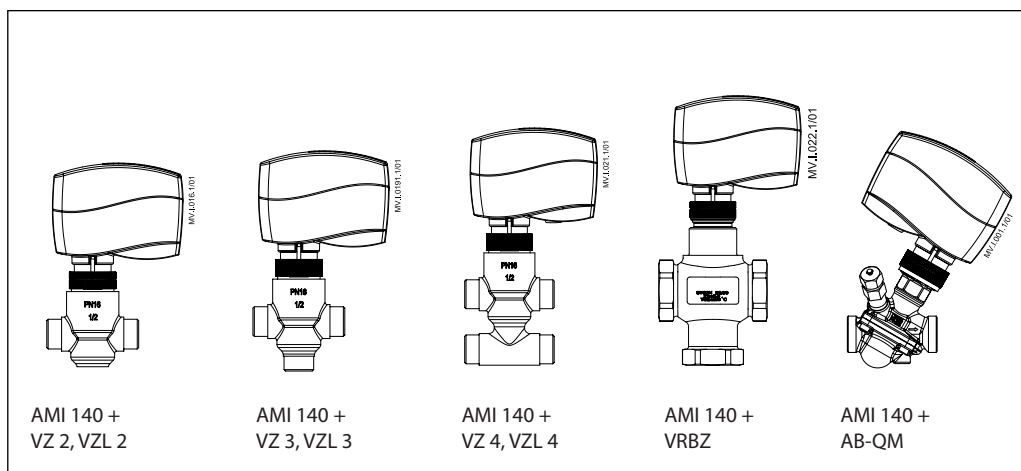

Dimensions (mm)

