

Data sheet

Actuator for modulating control AME 85QM

Description



AME 85QM actuator is used together with large pressure independent balancing and control valves type AB-QM DN 200 and DN 250.

Special features:

- position indication
- automatic adaptation of stroke to the valve's end position to reduce commissioning time (self stroking)
- advanced design incorporates load related "switch off" to ensure that actuators and valves are not exposed to overload
- manual operation

Main data:

- Nominal voltage:
- 24 VAC, 50 Hz/60 Hz
- Control input signal:
- 0(4)...20 mA
- 0(2) ... 10 V
- Force: 5.000 N
- Stroke: 40 mm
- Speed: 8 s/mm
- Max. medium temperature: 200 °C

Ordering

Type	Power supply	Speed	Code No.
AME 85QM	24 VAC	8 s/mm	082G1453

Technical data

Power supply	24 VAC, +10 to -15%
Power consumption	12.5 VA
Frequency	50 Hz / 60 Hz
Control input Y	0 ... 10 V (2 ... 10 V) Ri = 50 Ω, 0 ... 20 mA (4 ... 20 mA) Ri = 500 Ω
Output signal X	0 ... 10 V (2 to 10 V)
EMC	IEC 801/2 - 5
Close of force	5000 N
Max. stroke	40 mm
Speed	8 s/mm
Max. medium temperature	200 °C
Ambient temperature	0 ... 55 °C
Storage and transport temperature	-40 ... +70 °C
Degree of protection	IP 54
Protection class	II
Weight	9.8 kg
 - marking in accordance with standards	Low Voltage Directive (LVD) 2006/95/EC: EN 60730-1, EN 60730-2-14 EMC Directive 2004/108/EC: EN 61000-6-2, EN 61000-6-3

Installation

Mechanical

Installation of the valve with the actuator is allowed in horizontal position or upwards. Installation downwards is not allowed. Use the 57 mm castellated nut (supplied) to fit the actuator to the valve body. While the actuator is being fitted, a 8 mm Allan key can be used to tighten the pinch screw in the valve body ring to stop the valve turning.

Allow for necessary clearance for maintenance purposes.

Electrical

Electrical connections can be accessed by removing the actuator cover. Two cable gland entries with thread (M20 x 1.5 and M16 x 1.5) are prepared for cable glands.

Note: Cable and cable gland used must not compromise the actuator's IP rating, and must ensure the connectors are fully strain relieved. Please observe local rules and regulations as well.

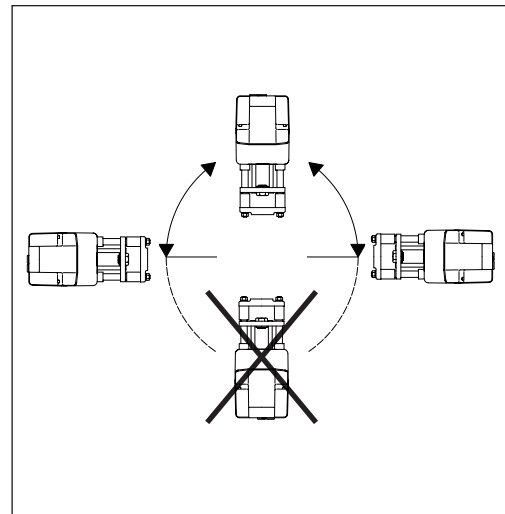

Wiring



Wiring for modulating control

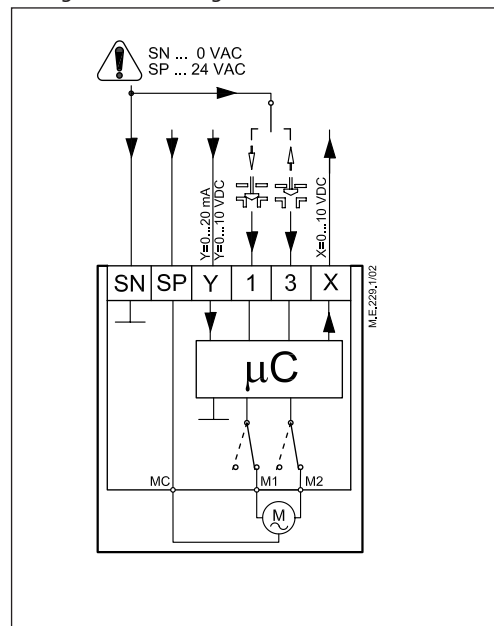

Wiring for 3-point control

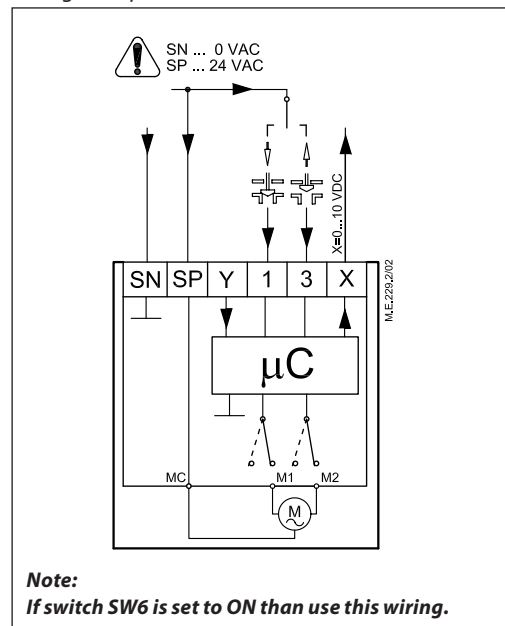

Wiring length	Recommended square of the wiring
0 - 50 m	0.75 mm ²
> 50 m	1.5 mm ²

- SP 24 V~ Power supply
- SN 0 V Common
- Y 0 to 10 V Input signal
(2 to 10 V)
0 to 20 mA
(4 to 20 mA)
- X 0 to 10 V Output signal
(2 to 10 V)

Automatic self stroking feature

When power is first applied, the actuator will automatically adjust to the length of the valve stroke. Subsequently, the self stroking feature can be re-initialised by changing position of SW9.

Diagnostic LED

The red diagnostic LED is located on the pcb under the cover. It provides indication of three operational states: Actuator Healthy (Permanently ON), Self Stroking (Flashes once per second), Error (Flashes 3 times per second - seek technical assistance).

DIP switch setting

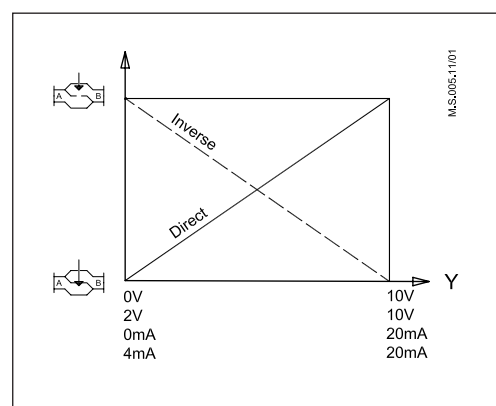
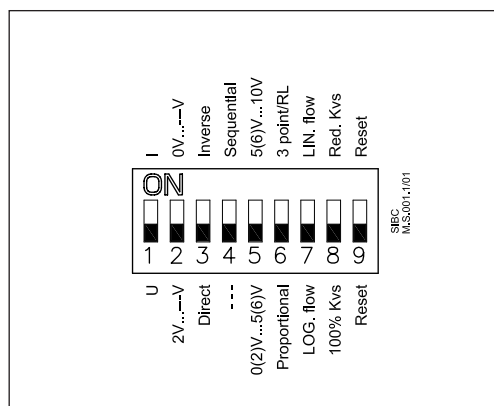

The actuator has a function selection DIP switch under the removable cover. In particular, if SW6 is set to ON, the actuator will perform as 3-point actuator. The switch provides the following functions:

- **SW1: U/I - Input signal type selector:**
If set to OFF position, voltage input is selected. If set to ON position, current input is selected.
- **SW2: 0/2 - Input signal range selector:**
If set to OFF position, the input signal is in the range from 2 V to 10 V (voltage input) or from 4 mA to 20 mA (current input). If set to ON position, the input signal is in the range from 0 V to 10 V (voltage input) or from 0 mA to 20 mA (current input).
- **SW3: D/I - Direct or inverse acting selector:**
If set to OFF position, stem retracts as voltage increases. If set to ON position, stem extends as voltage increases.
- **SW4: —/Seq - Normal or sequential mode selector:**
If set to OFF position, the actuator is working in range 0(2)..10V or 0(4)..20mA. If set to ON position, the actuator is working in sequential range; 0(2)..5 (6)V or 0(4)..10 (12)mA or 5(6)..10V or 10(12)..20mA).

- **SW5: 0..5V/5...10V - Input signal range in sequential mode:**
If set to OFF position, the actuator is working in sequential range 0(2)..5 (6)V or 0(4)..10 (12)mA. If set to ON position, the actuator is working in sequential range; 5(6)..10V or 10(12)..20mA.

- **SW6: Prop./3-pnt - Modulating or 3-point mode selector:**
If set to OFF position, the actuator is working normally according to control signal. If set to ON position, the actuator is working as 3-point actuator.

For this operation please refer to page 2 (wiring for 3-point control).

When DIP switch SW6 is set to ON than all functions from other DIP switches become inactive.

- **SW7: LOG/LIN - Equal percentage or linear flow through valve selector¹:**
If set to OFF position, the flow through valve is equal percentage. If set to ON position, the flow through valve is linear according to control signal.

- **SW8: 100% K_{VS} /Reduced K_{VS}**
To be set to OFF position.

- **SW9: Reset:**
Changing this switch position will cause the actuator to go through a self stroking cycle.

Commissioning

Complete the mechanical and electrical installation and perform the necessary checks and tests:

- Isolate control medium. (e.g. self stroking in a steam application without suitable mechanical isolation could cause a hazard).
- Apply the power. Note that the actuator will now perform the self stroking function.
- Apply the appropriate control signal and check the valve stem direction is correct for the application.
- Ensure that the actuator drives the valve over its full stroke, by applying the appropriate control signal. This action will set the valve stroke length.

The unit is now fully commissioned.

Commissioning / testing feature

The actuator can be driven to the fully open or closed positions (depending on valve type) by connecting SN to terminals 1 or 3.

Manual operation

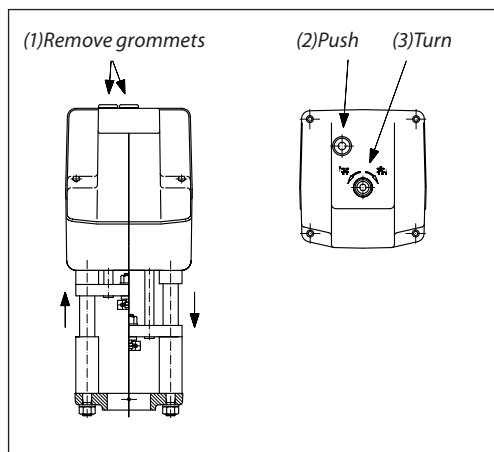

The manual operation is applied by rotating the 8 mm Allan key (not supplied) to the required position. Observe the direction of rotation symbol.

- Disconnect power
- Remove grommets and push the button
- Adjust valve position using an 8 mm Allan key
- Set valve to closed position
- Restore power

Note:
Actuator will restore position required by Y signal.

Actuator - valve combination

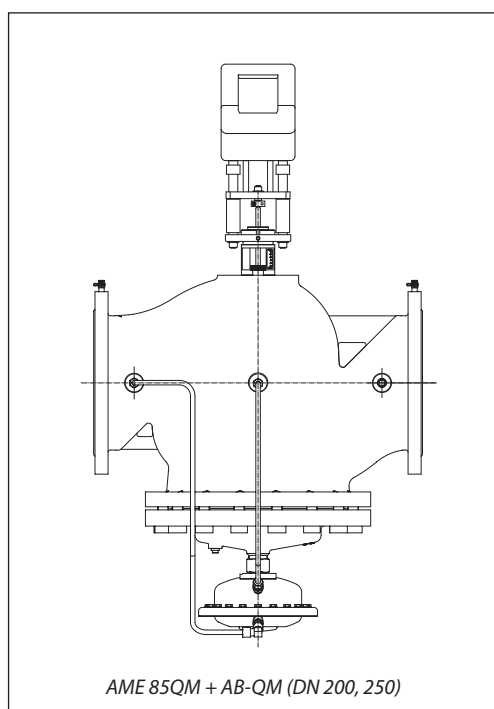

Dimensions (mm)

