

Data sheet

Automatic balancing valve ASV-I (DN 15-50)

Description



ASV-I is a partner valve to be used together with the automatic balancing valves ASV-PV/P to control differential pressure in the risers where the radiator valves have no presetting facilities. It is a combined adjustment and shut-off valve designed for installation in the flow pipe. It incorporates flow limitation so that it can be set for required maximum flow in the riser. ASV-I is supplied with rectus measuring nipples so that flow in the pipe can be measured. The valve (DN 15-40) is packaged in styropore (EPS) which can be used for insulation at temperatures up to 80 °C. An insulation cap is available as an accessory for insulation at higher temperatures (up to 120 °C).

Ordering

NOTE: for whole range of ASV partner valves, spare parts and accessories please refer to ASV datasheet.

ASV-I adjustment valve, inclusive two measuring nipples

Type	DN	k_{vs} (m ³ /h)	Internal thread (ISO 7/1)	Code No.	Type	External thread (ISO 228/1)	Code No.
	15	1,6	R _p 1/2	003L7641		G 3/4 A	003L7646
	20	2,5	R _p 3/4	003L7642		G 1 A	003L7647
	25	4,0	R _p 1	003L7643		G 1 1/4 A	003L7648
	32	6,3	R _p 1 1/4	003L7644		G 1 1/2 A	003L7649
	40	10	R _p 1 1/2	003L7645		G 1 3/4 A	003L7650
	50	16				G 2 1/4 A	003L7652

Accessories and spare parts

Type	Description	Comments/connection	Code No.
	Shut-off knob for ASV-I (black)	DN 15	003L8155
		DN 20	003L8156
		DN 25	003L8157
		DN 32 / DN 40 / DN 50	003L8158
	Two test plugs and one locking plate	For ASV-I and ASV-M, rectus type (DN 15-40)	003L8145
	Plug for impulse tube connection ASV-I/M	Set of 10 pieces / G 1/16 A	003L8174

Technical data

Nominal diameter	DN	15-50
Max. pressure	bar	16 (PN 16)
Test pressure		25
Differential pressure over the valve	kPa	10-150 ¹⁾
Temperature	°C	-20 ... 120
Material of parts in contact with water		
Valve body		Brass
Membrane / O-rings		EPDM
Spring		Stainless steel

¹⁾ Please note that the maximum admissible differential pressure across the valve 150 kPa should also not be exceeded at partial load.

Application

ASV-I has to be used as partner valve inside control loop (Fig. 1). ASV-I and ASV-P(V) is connected via an impulse tube, and there by giving a constant differential pressure across the riser and ASV-I.

This configuration offers flow limitation on the riser however part of the controlled pressure range is used by pressure drop on partner valve (Δp_v). It is recommended when flow limitation on each terminal units is not possible.

This way it is possible to control the maximum flow for each riser, and ensuring distribution between them.

- partner valve inside control loop (Fig. 1). Offers flow limitation on the riser however part of the controlled pressure range is used by pressure drop on partner valve (Δp_v). It is recommended when flow limitation on each terminal units is not possible.

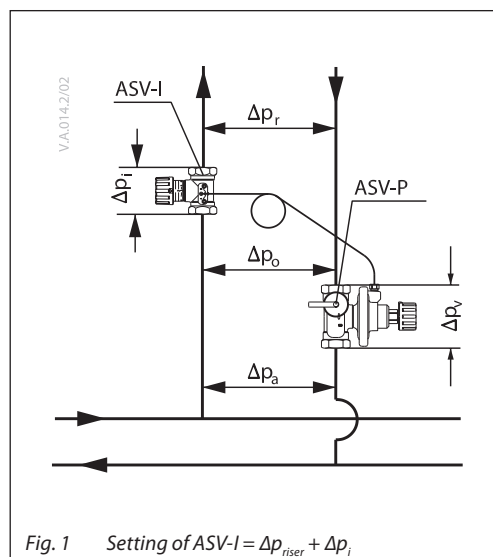

Design

1. Shut-off knob
2. Shut-off spindle
3. Setting spindle
4. Scale disc
5. O-rings
6. Valve cone
7. Seat
8. Valve body

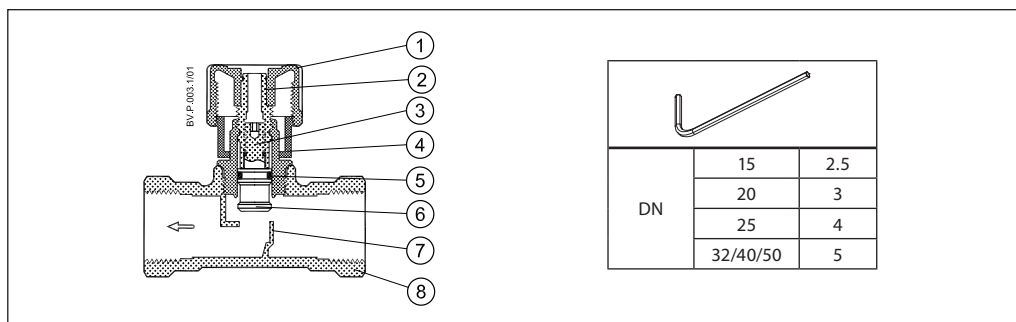

ASV-I incorporates a double cone able to give maximum stroke limitation, thus achieving flow limitation. It also incorporates shut off function. ASV-I is equipped with the nipples for the flow measurement and a connection for the ASV-I/ASV-PV impulse tube.

Use the following procedure to limit the flow: turn the valve knob fully counter clockwise to open the valve. The mark on the knob will now be opposite »0« on the scale. Turn the valve knob clockwise to the required setting (e.g. for setting 2.2 the knob must be rotated two full turns and then forward to »2« on the scale. Hold the knob to keep the setting (e.g. 2.2) and using a

hexagon socket key turn the spindle fully counter clockwise (until a stop can be felt). Turn the valve knob fully counter clockwise so that the mark on the knob is opposite »0« on the scale.

The valve is now open as many turns from the closed position (2.2) as indicated by the conversion from required flow. To annul the setting, turn the hexagon socket key fully clockwise (until a stop can be felt).

Remember, at the same time the knob must be held on its »0« setting.

To read presetting valve has to be closed.

Sizing

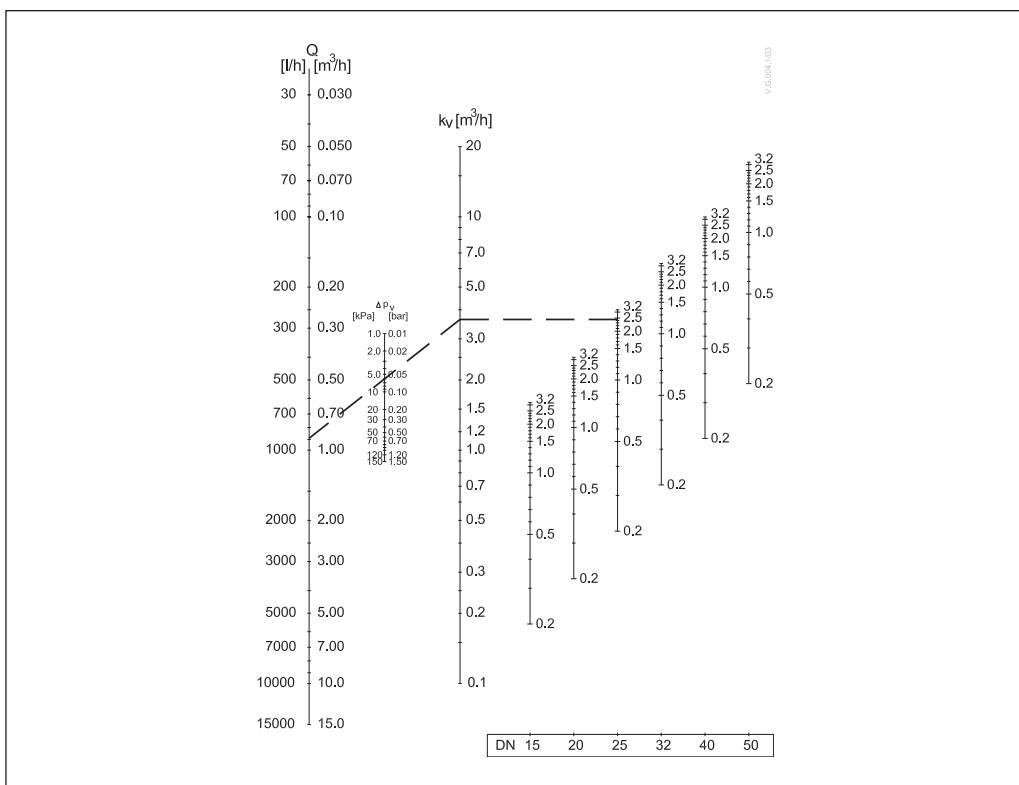

Dimensions

